

SPIRAL CONVEYOR

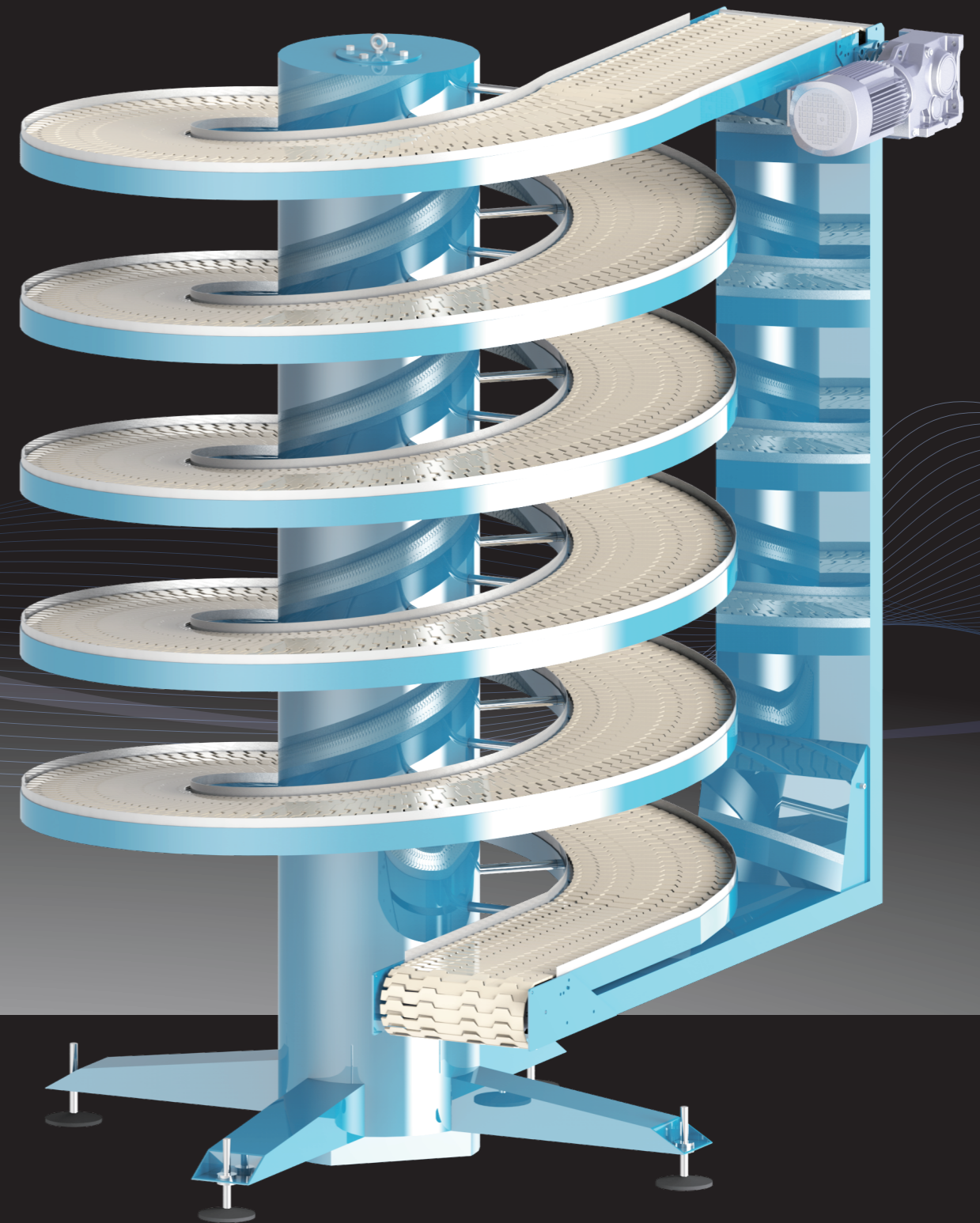

 **NEXUS** Engineering Corp.
www.nexus-spiral.com



Affordable Price
Innovative Design
Simple Installation
Easy Maintenance
Customization Service
Flexible Layout
Optimized Space

Dual track spiral conveyor

What Dual-track (Multi-track) spiral conveyor can achieve

- ◆ Diverting with coaxial multi-track
- ◆ Different direction (upwards and downwards) of two tracks
- ◆ Minimized footprint
- ◆ Different speed of two tracks
- ◆ Flexible layout

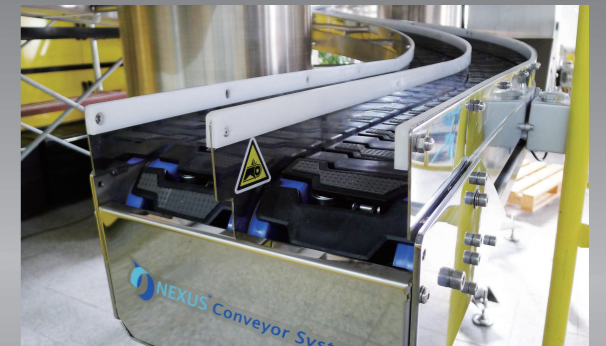
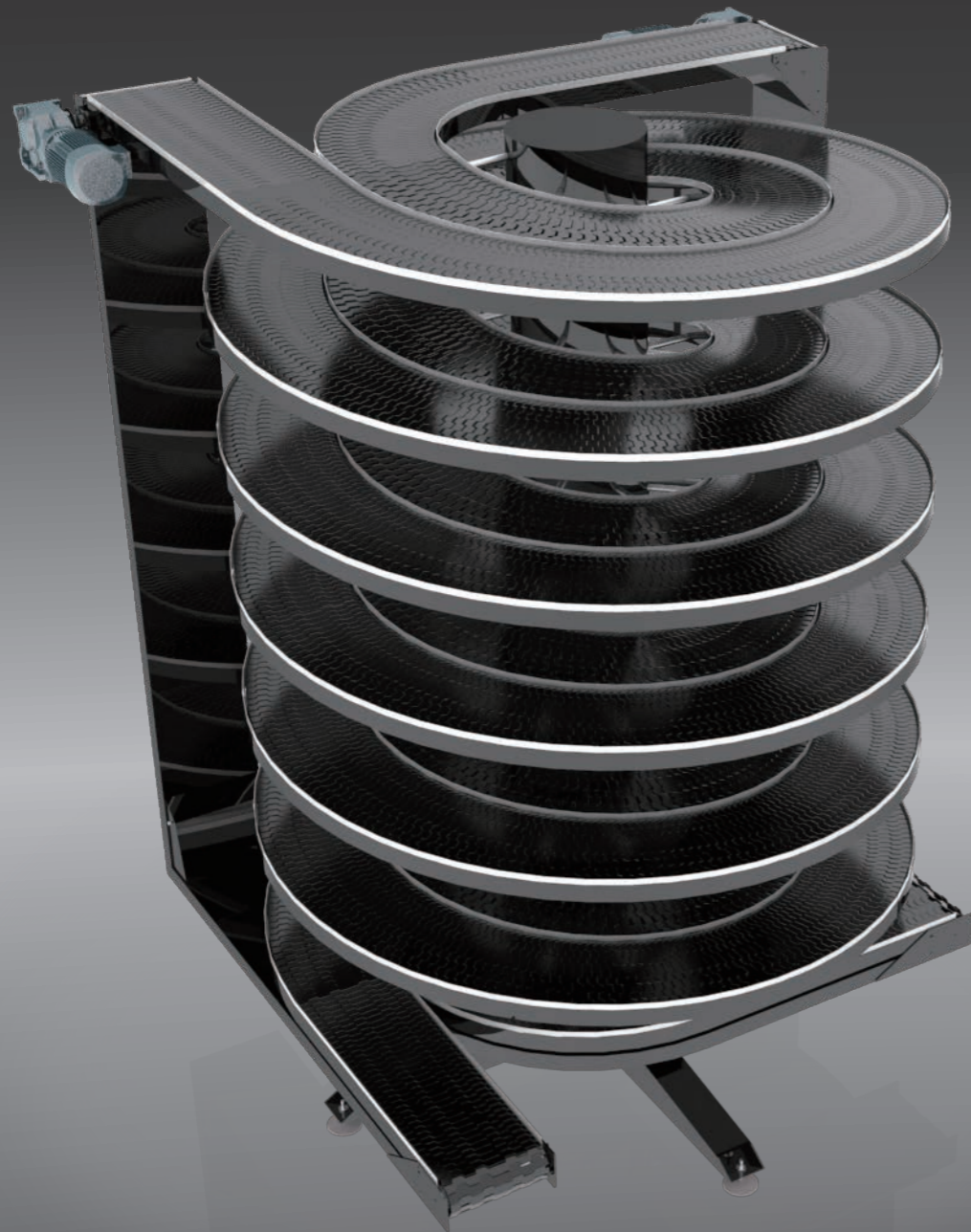

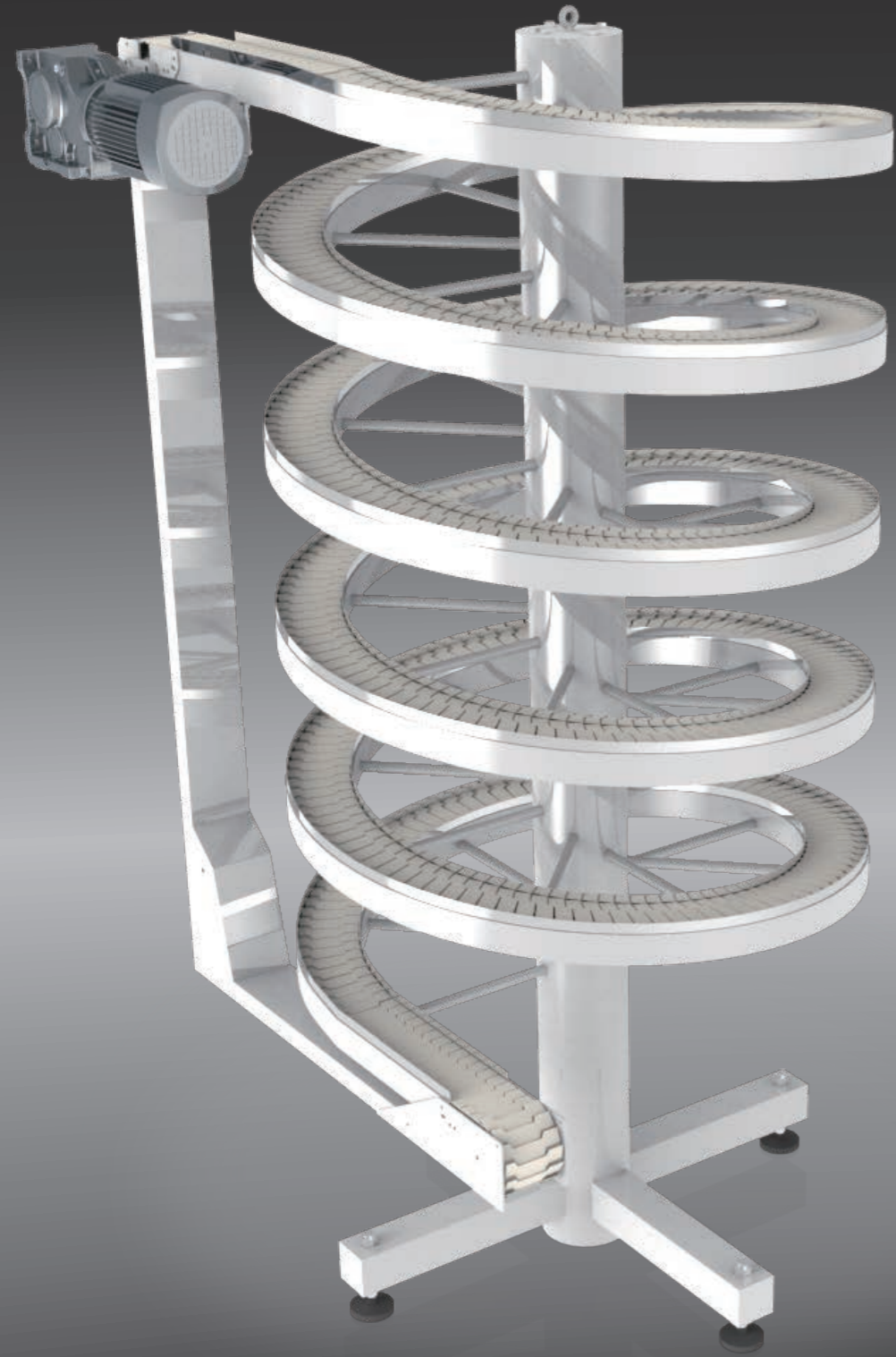

Narrow track spiral conveyor

Compact design of it brings minimized footprint and power consumption, and are especially suitable for the light-duty conveying of small size objects.

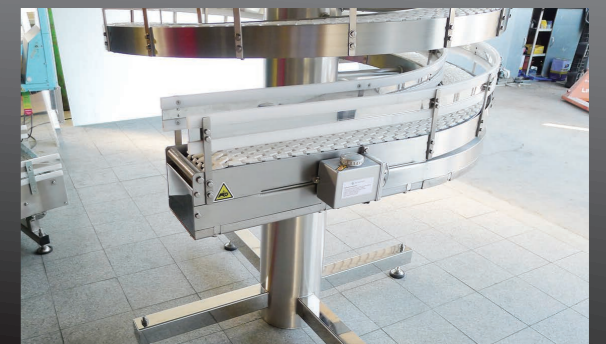

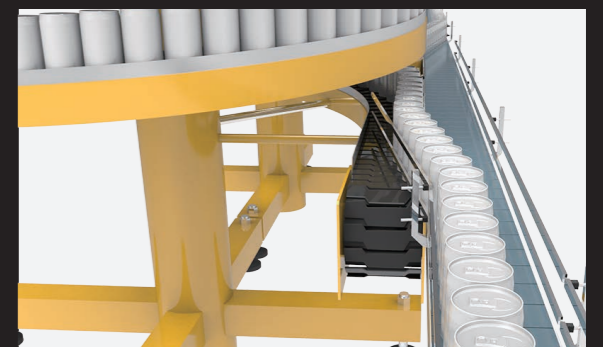
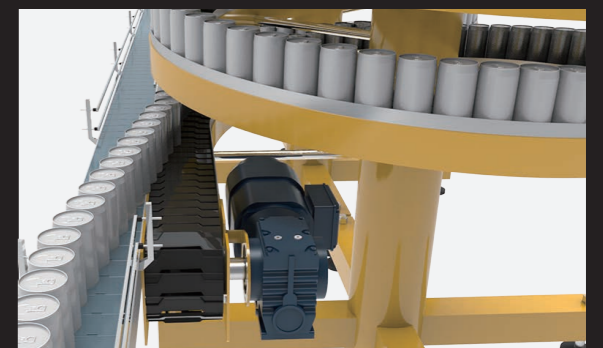
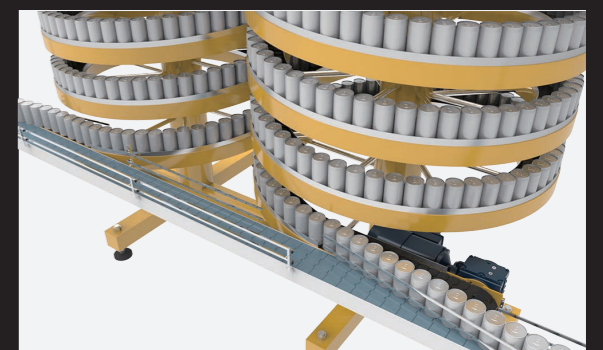
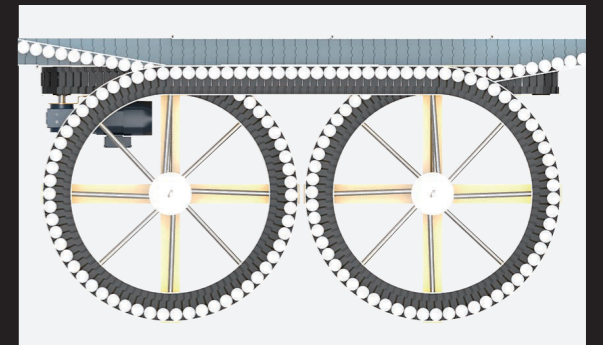
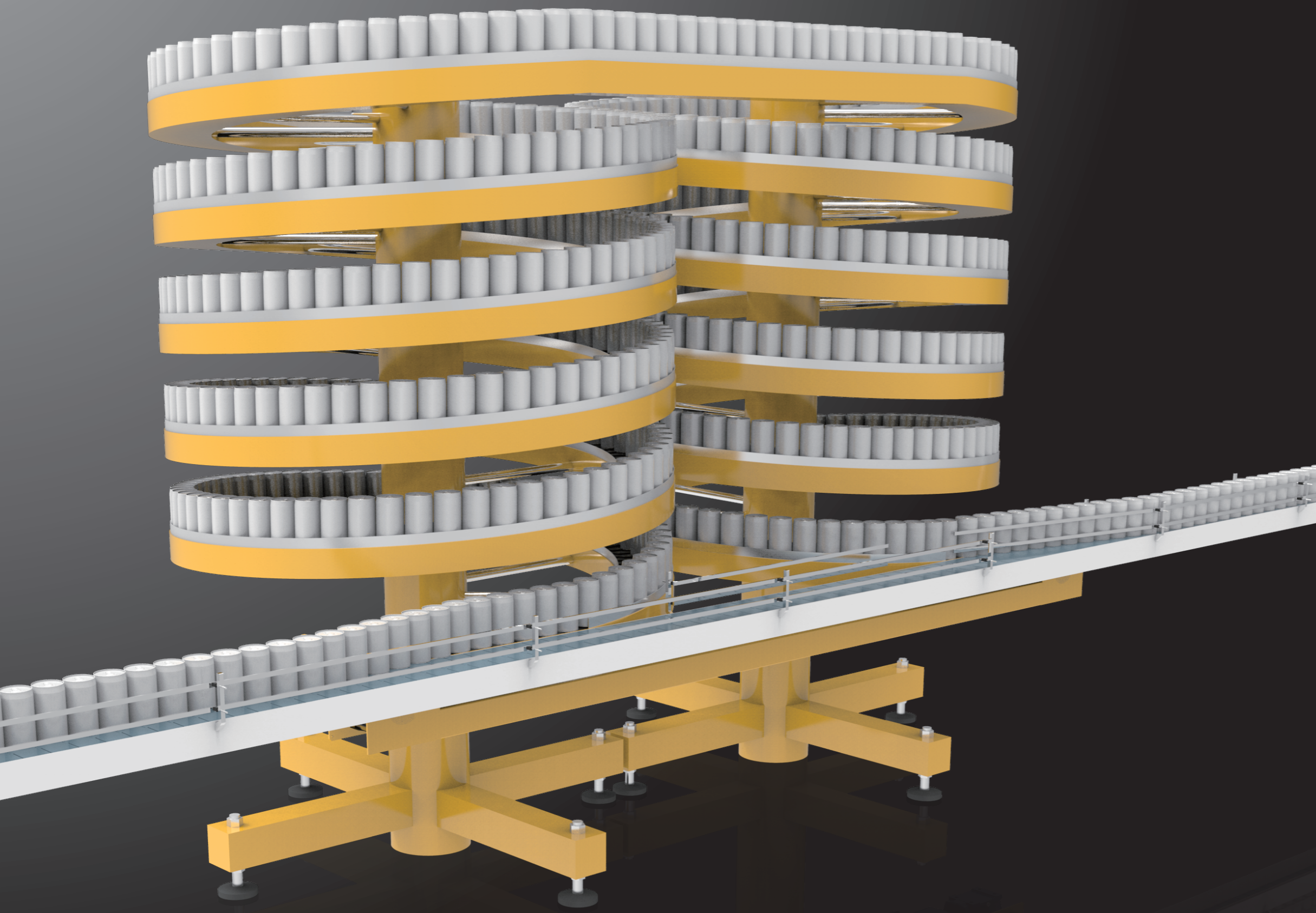

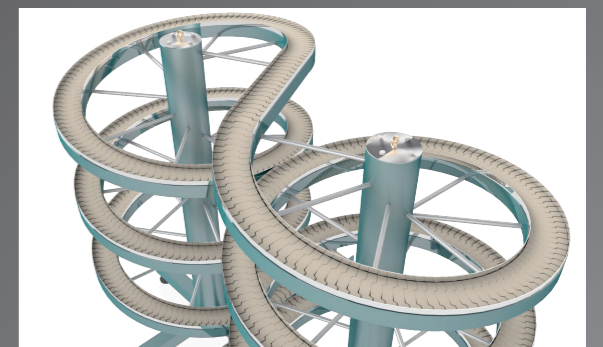
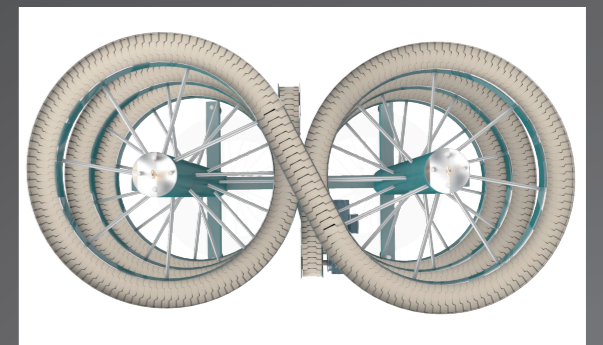
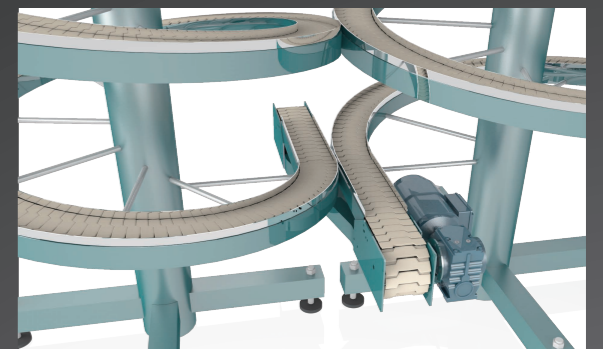
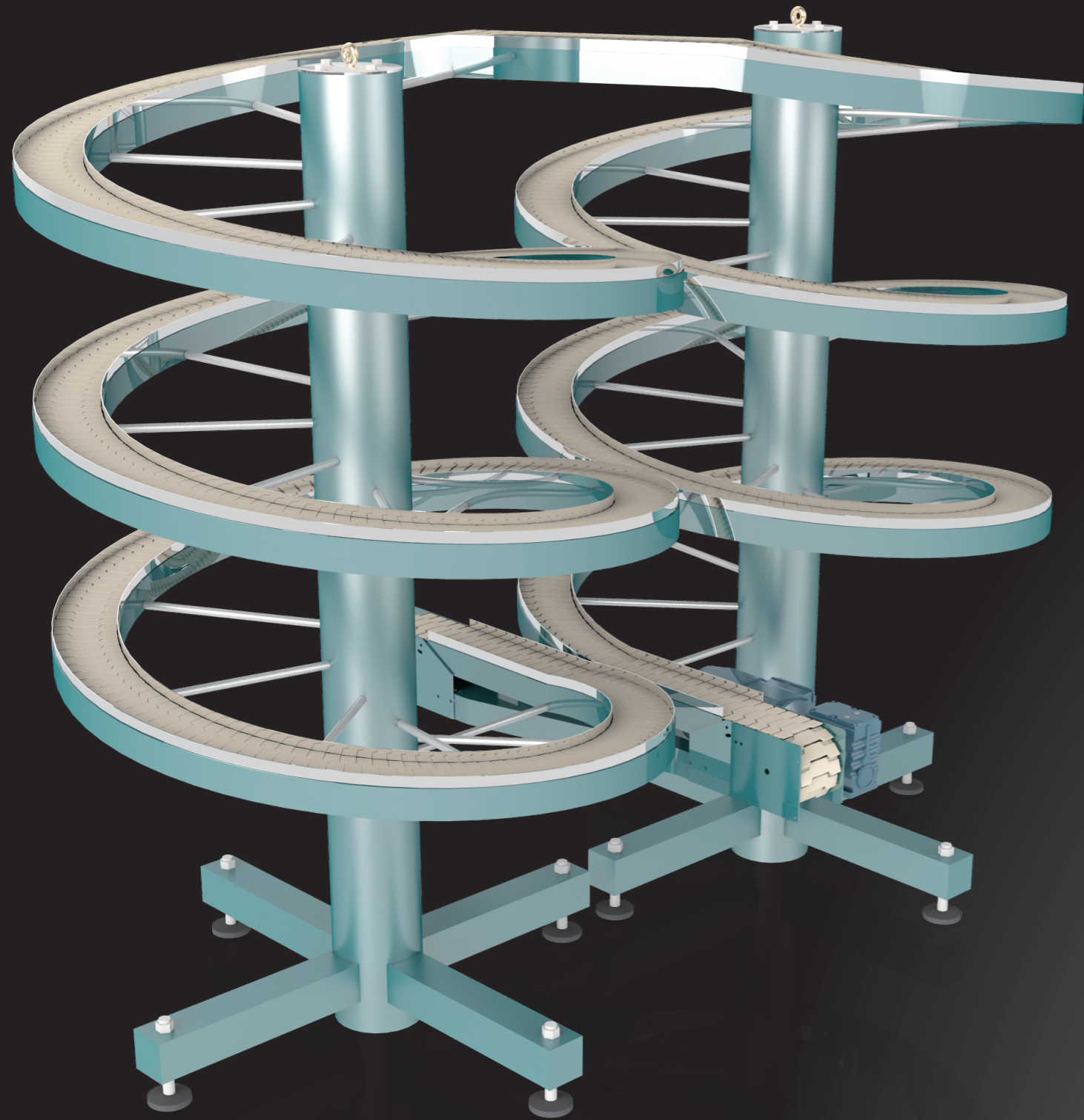

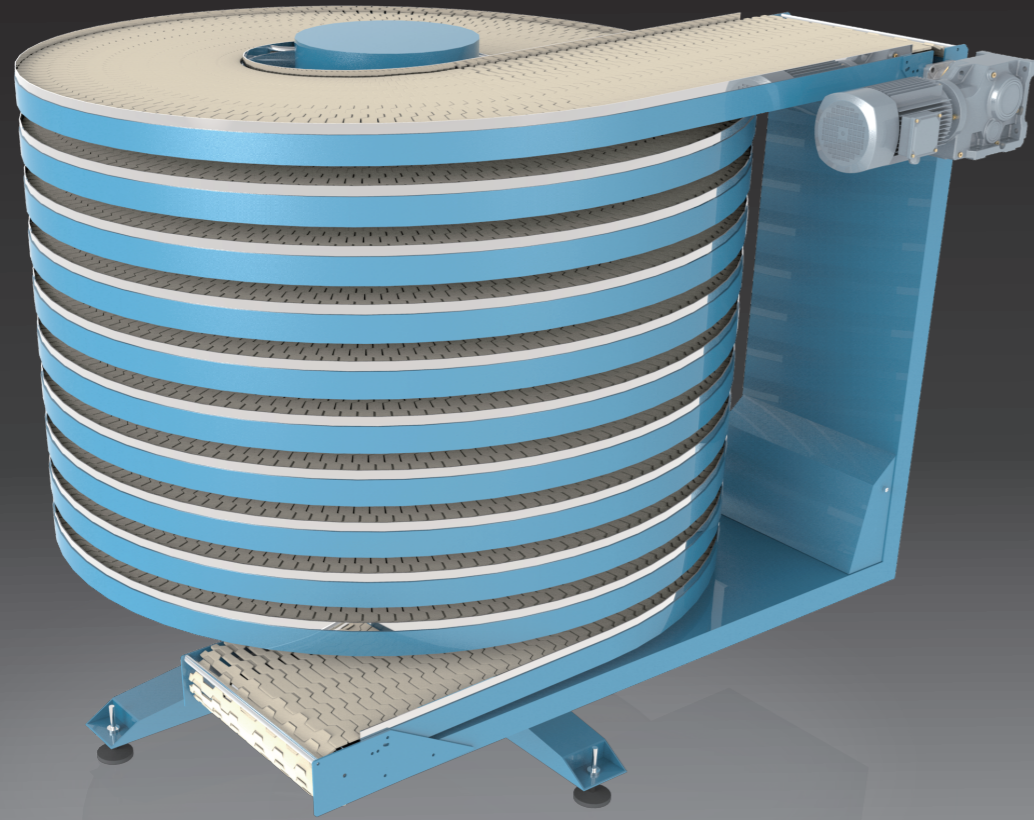

Cooling spiral conveyor

Application for conveyance based on space-saving superiority with maximum running route and time. Mainly used for the cooling or drying of products.

Customization

Conveyors with special specification are customizable to satisfy the application.

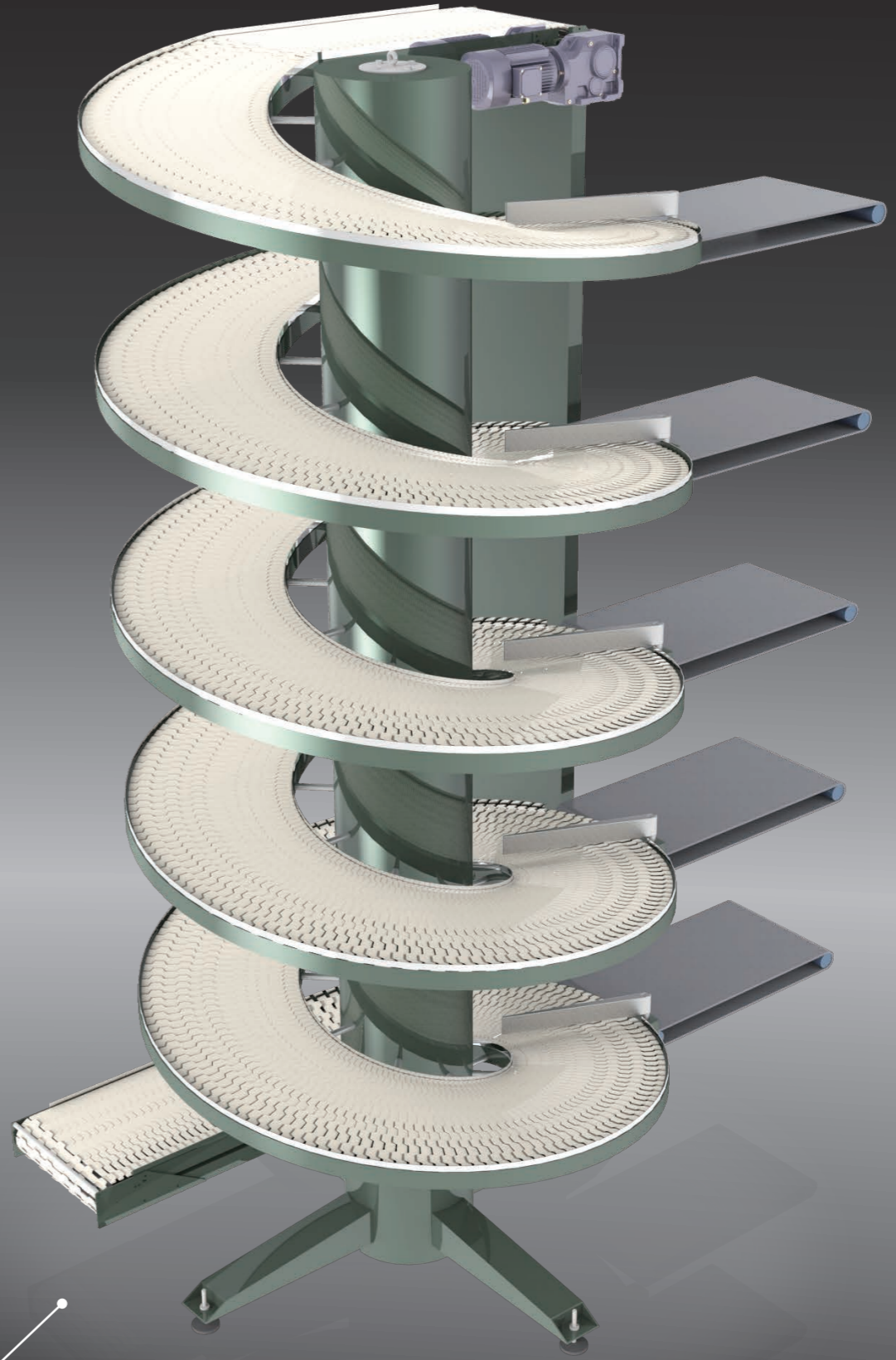

Multiple inlet and outlet spiral conveyor

Multiple inlet and outlet achieves products enter or exit the spiral conveyor in different floor, and are widely used in Internal logistics and warehousing industry.

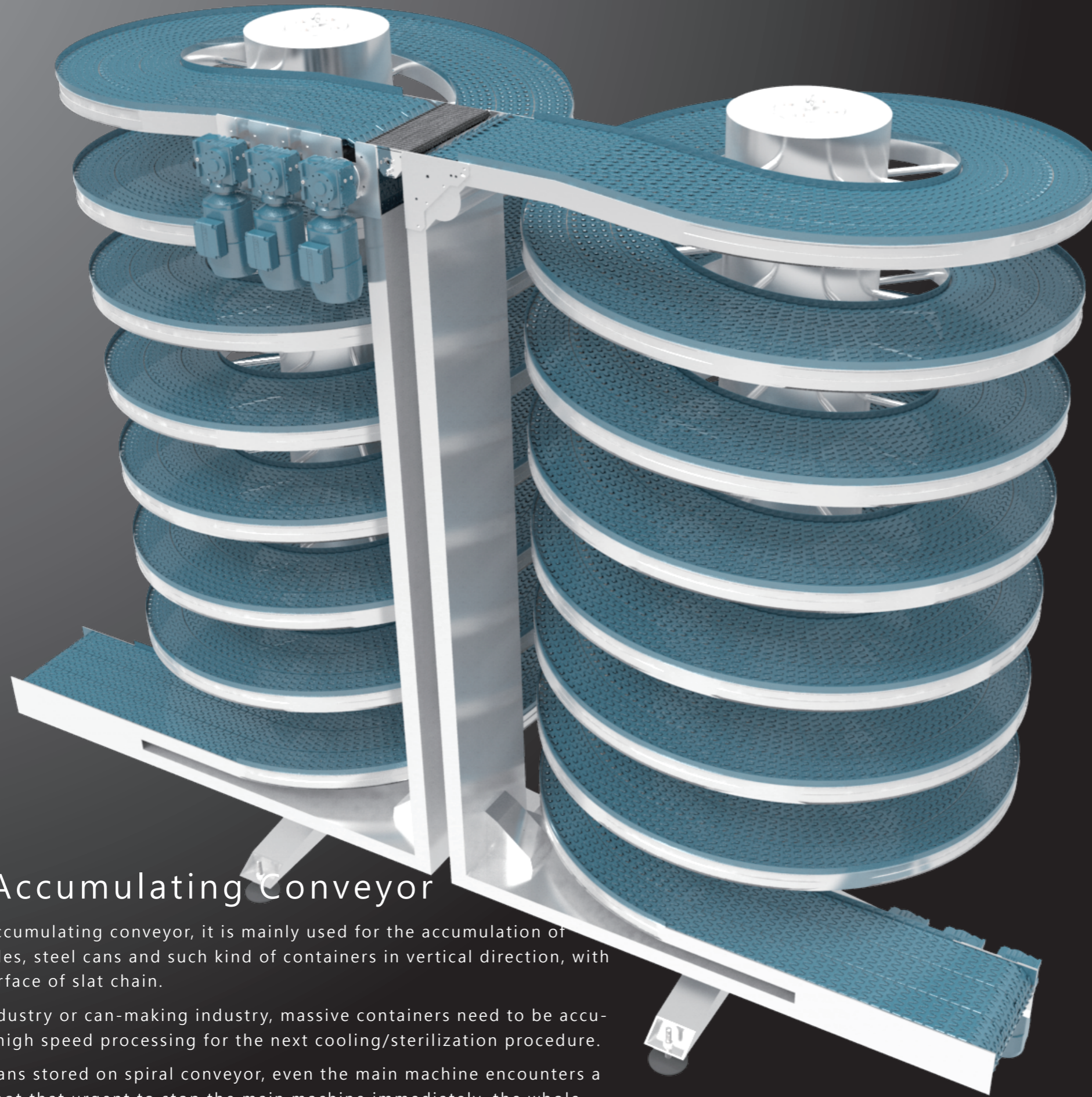

Spiral Accumulating Conveyor

Nexus spiral accumulating conveyor, it is mainly used for the accumulation of glass/PET bottles, steel cans and such kind of containers in vertical direction, with full load on surface of slat chain.

In beverage industry or can-making industry, massive containers need to be accumulated after high speed processing for the next cooling/sterilization procedure.

With bottles/cans stored on spiral conveyor, even the main machine encounters a problem, it is not that urgent to stop the main machine immediately, the whole production process will be not affected in certain time, so it will reduce downtime and maximize throughput.

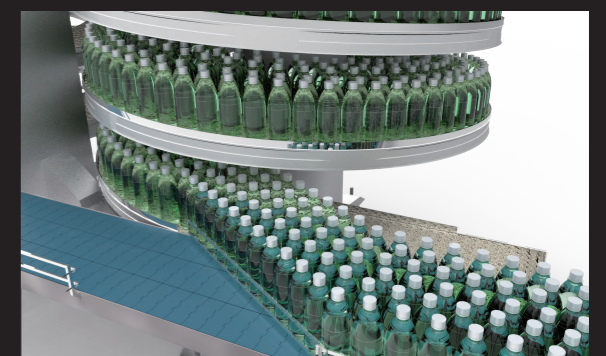
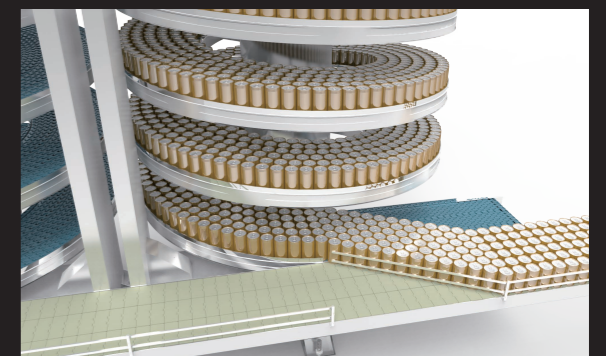
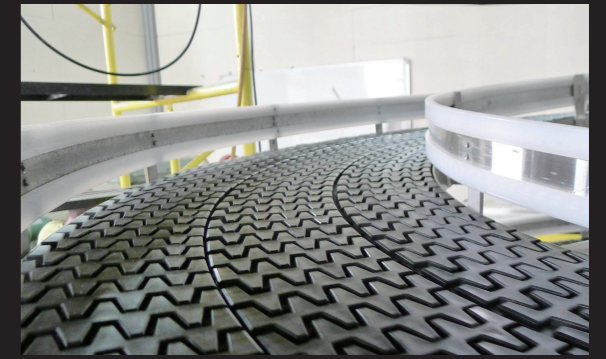

Light Duty Spiral Conveyor

For general transportation, heavy duty load capacity is not required. NEXUS light duty spiral conveyor is developed to meet the needs of light loading application.

Compared with standard spiral conveyor, frame of light duty spiral conveyor is simplified due to delicate design. However, quality and function of the spiral conveyor are maintained and are not affected because of it.

We do our best to lower the cost of manufacture and marketing, just to provide the users with high cost performance products which suitable for light duty transportation.

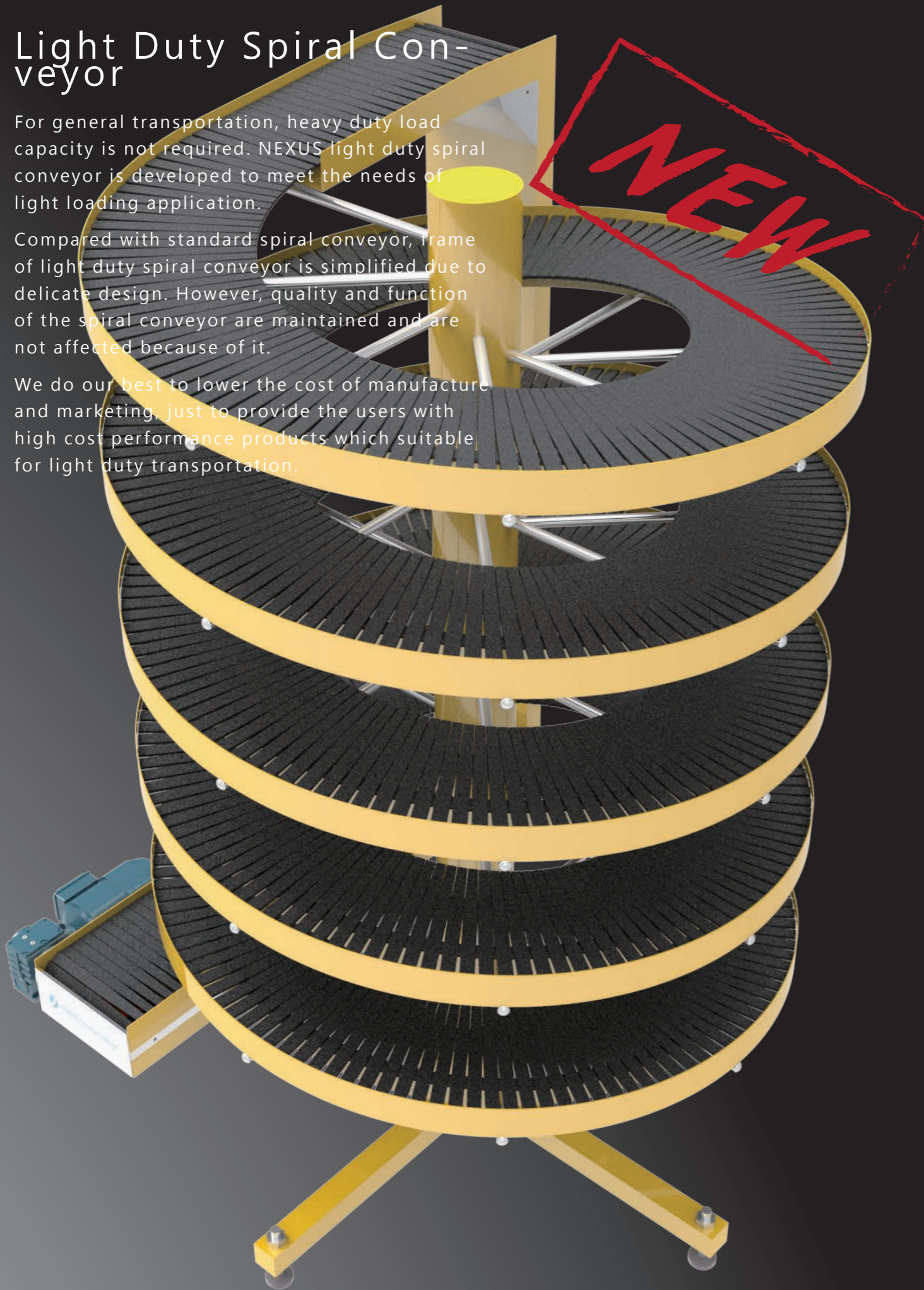

Difference Table Standard VS Light-duty

Item	Conditions	Unit Load Spiral Conveyor	
		Standard	Light-duty
Side Guard	Inner side guard	25mm	None
	Outer side guard	25mm	25mm
	Heighten the side guard	Optional	Optional
Slat Chain	Type of slat chain	Zigzag	Flat
Support Rail	Number of support rail under slat chain	4	2
	Extra rail support	No need	Add to 4 (Optional)
Load capacity	Max. unit load capacity (kg/M ²)	50	25 ~ 40
Applicable product	Carton (Hard)	Approved	300mm (Min.)
	Irregularly shaped packaging (Soft)	Approved	Not recommended
	Buck items	Approved	Not recommended
Position of product	The products locate in central of slat chain	Not required	Required
Side transfer	Both Leading-in and leading-out	Approved	Not recommended
Guidance device	Guidance device in inlet&outlet	Optional	Optional
Auxiliary roller	Auxiliary roller in inlet & outlet	Installed	None
Bottom sealing plate	Sealing plate under support rail of slat chain	Installed	Optional
Central drum	Diameter of central drum (mm)	508	267
Frame material	Stainless steel material	Optional	Not recommended
	Mild steel painted	Optional	Optional
Paint	Paint of mild steel material	Automobile-level waterproof paint	Normal painting
Price	Price lever of two types	100%	70~80%

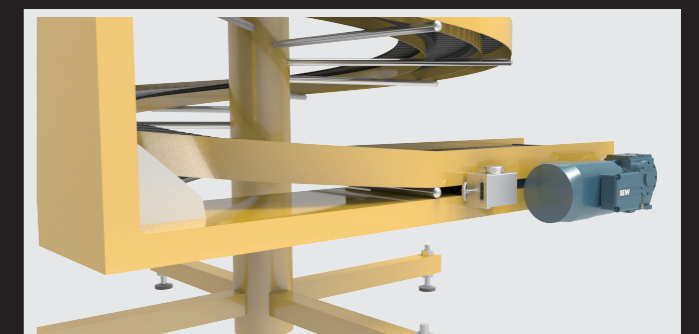
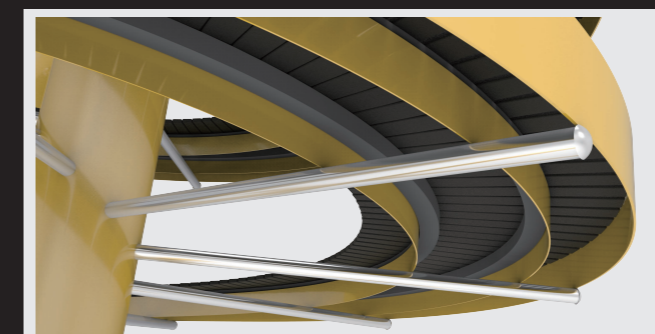
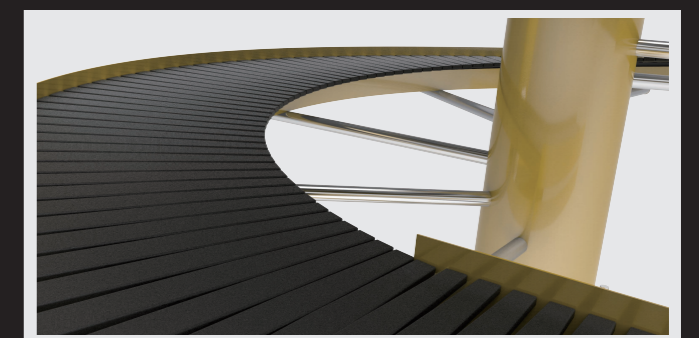

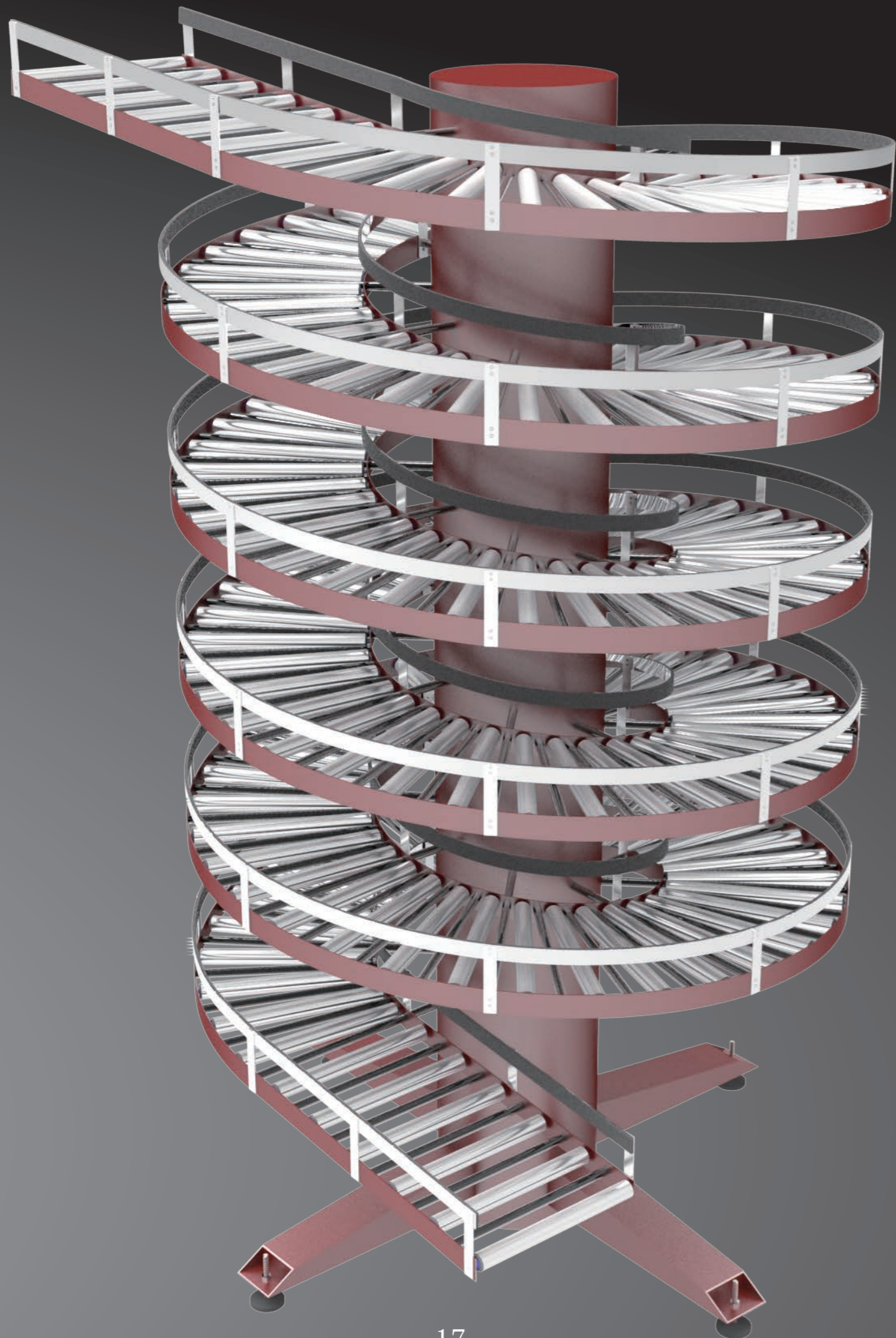

Gravity Roller Spiral Conveyor

NEXUS gravity roller spiral conveyor, with high-quality unpowered rollers installed, achieving gentle transportation of product without power consumption.

Both roller width and number of layers are customized. Multi-entry transportation is available by installing sensors and other electronic control unit. For high-rise buildings it has incomparable advantages.

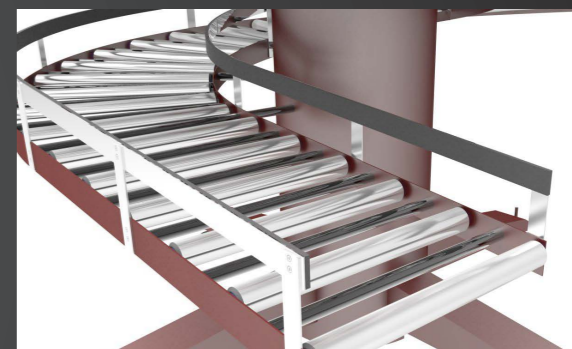
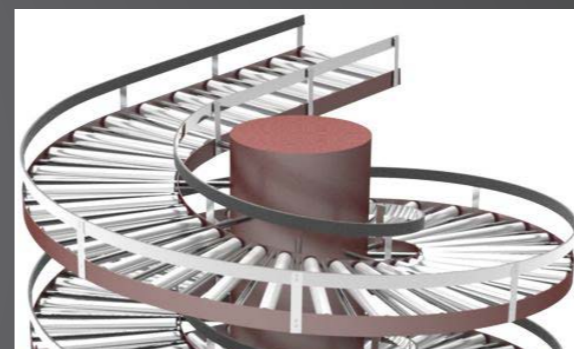



Innovative Design

Sometimes mechanical problems are complicated but the solutions are surprisingly simple. With new ideas and patent in technique, we achieve innovations on design and simplify the work maintenance and installation to the utmost extent, including automatic lubrication system (ALS) and tension adjustment (patented).

Top Quality

◆ Frame

The frame is deftly designed and made with stainless steel or mild steel; Other supports are double-coated (primer + topcoat). These materials ensure that products are durable and have a long product life.

◆ Accessories

We are selective about all of the accessories used: rigid chain and high-quality bearings lower noise level, ensures low-friction, durability, smooth operation and long life span.

Easy Maintenance

We are committed to prevent and prepare for unavoidable wear and tear upon conveyors. Overload protection, Chain over-length sensor and auto lubrication device ensure smoothly running, as well as prolonging life time of spiral conveyor.

Simple Installation

Our standard spiral conveyor is designed to perfectly fit the size of the container. The ready-to-run conveyor can be shipped on a pallet; when arriving on site, it simply requires positioning (the weight of conveyor is so light that can be lifted by hand pallet truck), leveling and electrical connection. The ease of installation saves you labor costs.

*On-site integration service is available for spiral conveyor with special design or specifications.

Customization Service

The choice of colors, materials and the application of auto control system of the spiral conveyor are in your hands.

Low Noise

Operational noise is only around 60dB (normal conversation is at 60-70dB), providing you a comfortable working environment.



Lubrication device

Manual operation lubrication device is standard equipped in NEXUS spiral conveyors. Electronic Auto-timing lubrication device is optional, please consult our sales team or contact your local agent of NEXUS.



Excellent Lacquering

In contrast to the inferior manual painting of other brands that causes uneven surface and color leading to difficulty in cleaning. Our quality painting technique guarantees you the highest quality.





Connection

Depending on the dimension of loads, different transfer ways are optional. NEXUS Miniature conveyors are highly recommended, which is designed and produced to achieve perfect transition. Please consult our sales department to get detailed information.

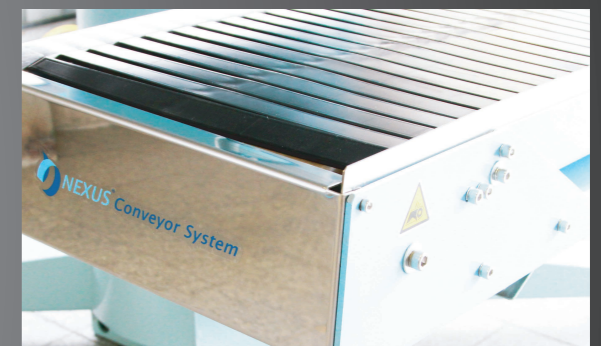
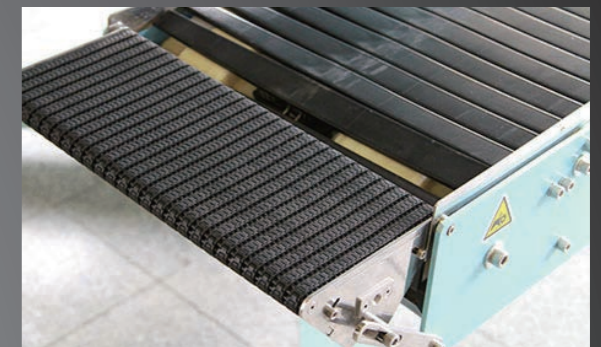

Technical data

- ◆ Standard specification of slat chain:
420mm (available width is 400mm)
620mm (available width is 600mm)
- ◆ The maximum height of spiral conveyor is 10M.
The maximum number of turns is 10.
- ◆ Outer diameter:
Outer diameter of type 400 is 1800mm.
Outer diameter of type 600 is 2000mm.
- ◆ NEXUS spiral conveyors are made from mild steered painted or stainless steel material; These two kinds of material can be also specified as material of transmission chain.

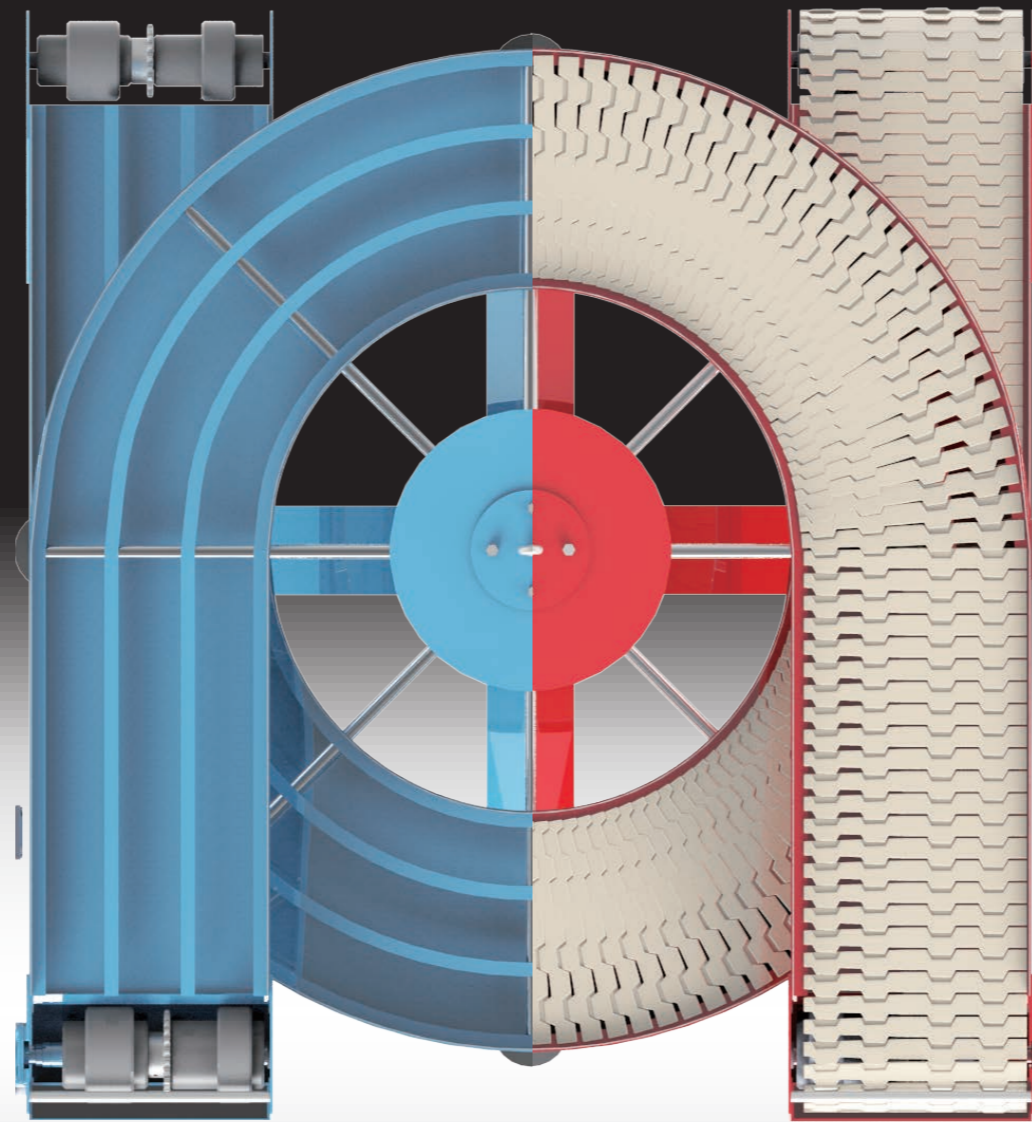

The maximum load capacity and speed

- ◆ Maximum speed of NEXUS spiral conveyor is 60m/min, automatic lubricator should be installed to prolong the product' s life when speed exceeds 35m/min.
- ◆ Please supply your detailed requirements of the maximum load capacity and speed to enable us to choose correct drive motor.
- ◆ If adjustable speed is needed, please specify speed range in advance, so we can equip the spiral conveyor with proper frequency converter.

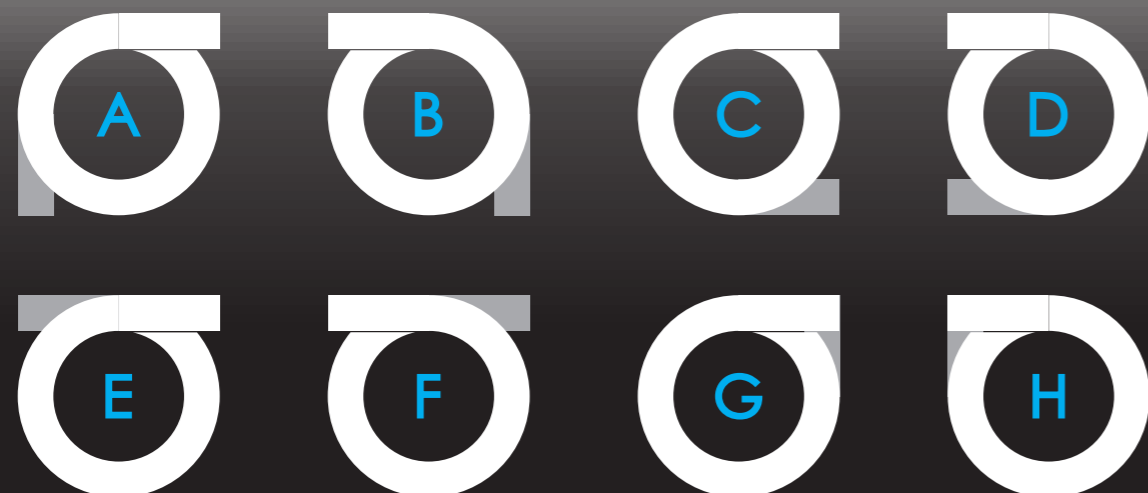

- ◆ Any width of the slat chain less than 600mm can be processed
- ◆ In our company there is slat chain with special structure design available for your choice, which is heat resistant to 80+ degrees C. Please consult our sales team if with demand.

Series	Code	Width	Pitch	Load capacity		Max speed	Temperature
				Stainless steel	Carbon steel		
Flat & Zigzag	SP-135F	135mm	19.05mm	40kg/M (MAX)	50kg/M (MAX)	60m/min	-10° c ~ 40° c
	SP-165F	165mm					
	SP-400F	400mm					
	SP-600F	600mm					

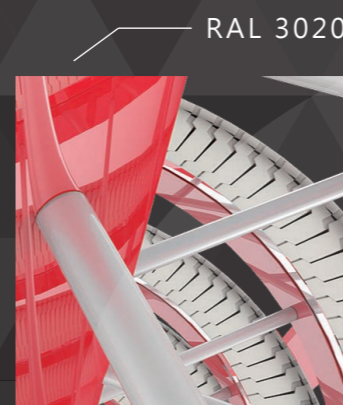
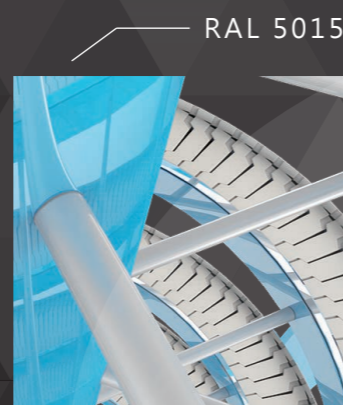
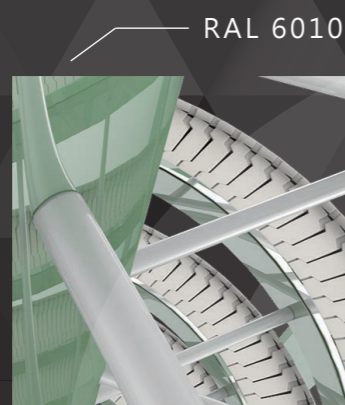
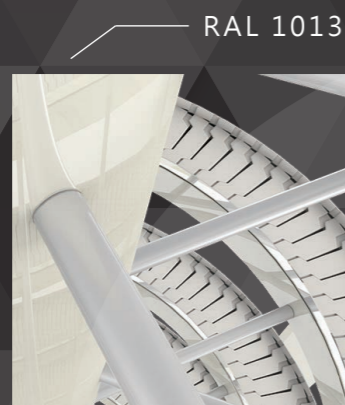

RAL K7

RAL 1000	RAL 1001	RAL 1002	RAL 1003	RAL 1004	RAL 1005	RAL 1006	RAL 1007	RAL 1011	RAL 1012	RAL 1013	RAL 1014	RAL 1015	RAL 1016	RAL 1017	RAL 1018
RAL 1019	RAL 1020	RAL 1021	RAL 1023	RAL 1024	RAL 1027	RAL 1028	RAL 1032	RAL 1033	RAL 1034	RAL 1037	RAL 2000	RAL 2001	RAL 2002	RAL 2003	RAL 2004
RAL 2008	RAL 2009	RAL 2010	RAL 2011	RAL 2012	RAL 3000	RAL 3001	RAL 3002	RAL 3003	RAL 3004	RAL 3005	RAL 3007	RAL 3009	RAL 3011	RAL 3012	RAL 3013
RAL 3014	RAL 3015	RAL 3016	RAL 3017	RAL 3018	RAL 3020	RAL 3022	RAL 3027	RAL 3028	RAL 3031	RAL 4001	RAL 4002	RAL 4003	RAL 4004	RAL 4005	RAL 4006
RAL 4007	RAL 4008	RAL 4009	RAL 4010	RAL 5000	RAL 5001	RAL 5002	RAL 5003	RAL 5004	RAL 5005	RAL 5007	RAL 5008	RAL 5009	RAL 5010	RAL 5011	RAL 5012
RAL 5013	RAL 5014	RAL 5015	RAL 5017	RAL 5018	RAL 5019	RAL 5020	RAL 5021	RAL 5022	RAL 5023	RAL 5024	RAL 6000	RAL 6001	RAL 6002	RAL 6003	RAL 6004
RAL 6005	RAL 6006	RAL 6007	RAL 6008	RAL 6009	RAL 6010	RAL 6011	RAL 6012	RAL 6013	RAL 6014	RAL 6015	RAL 6016	RAL 6017	RAL 6018	RAL 6019	RAL 6020
RAL 6021	RAL 6022	RAL 6024	RAL 6025	RAL 6026	RAL 6027	RAL 6028	RAL 6029	RAL 6032	RAL 6033	RAL 6034	RAL 6037	RAL 7000	RAL 7001	RAL 7002	RAL 7003
RAL 7004	RAL 7005	RAL 7006	RAL 7008	RAL 7009	RAL 7010	RAL 7011	RAL 7012	RAL 7013	RAL 7015	RAL 7016	RAL 7021	RAL 7022	RAL 7023	RAL 7024	RAL 7026
RAL 7030	RAL 7031	RAL 7032	RAL 7033	RAL 7034	RAL 7035	RAL 7036	RAL 7037	RAL 7038	RAL 7039	RAL 7040	RAL 7042	RAL 7043	RAL 7044	RAL 7045	RAL 7046
RAL 7047	RAL 8000	RAL 8001	RAL 8002	RAL 8003	RAL 8004	RAL 8007	RAL 8008	RAL 8011	RAL 8012	RAL 8014	RAL 8015	RAL 8016	RAL 8017	RAL 8019	RAL 8022
RAL 8023	RAL 8024	RAL 8025	RAL 8028	RAL 9001	RAL 9002	RAL 9003	RAL 9004	RAL 9005	RAL 9006	RAL 9007	RAL 9010	RAL 9011	RAL 9016	RAL 9017	RAL 9018
RAL 1035	RAL 1036	RAL 2013	RAL 3032	RAL 3033	RAL 4011	RAL 4012	RAL 5025	RAL 5026	RAL 6035	RAL 6036	RAL 7048	RAL 8029	RAL 9022	RAL 9023	RAL

* Different computer's monitors may lead to a difference in color tones, if a specific color tone is required, please send us the specific color sample by post.



Carbon Steel 7.5mm
Stainless Steel



Stainless Steel 2mm



Carbon Steel
Electroplated
Stainless Steel 27Ø



Carbon Steel
Stainless Steel
3mm



Carbon Steel
Electroplated
Stainless Steel 2mm

Slat chain

The slat chain is made from composite plastic material, which has the physical characteristics of high rigidity, high impact resistance and low friction. It can reduce the abrasion in the process of accumulation, as well as improving the stability and service life. Modular design simplify the work of maintenance and replacement.

Easy assembling

Without special tools or complicated procedure it can be assembled in transmission chain.



Hassle-free maintenance

Modular design of slat chain makes the replacement and maintenance as easy as playing Lego. You can purchase new slat chain from NEXUS to replace the old one; In the event of an emergency, you can also replace the worn parts (bearings and transmission chains) with same specification products as specified in our manual.



Outstanding load capacity and smooth operation

The Zigzag shape modules are of patented design: they interlace with each other and fit into the inter-space perfectly, avoiding interference caused by objects falling into the gap in operation. Load capacity is also enhanced because of the double-overlapping design.



Incline angle advice

- ◆ Rubber cover (TPE) with high friction coefficient can be added on this product.
- ◆ With low friction coefficient on the surface of plastic, incline angle for products made from plastic, Iron and Aluminum should be less than 7.2° to insure the most steady conveying.
- ◆ For cartons and other products with PE film, the incline angle should be less than 11.5° .
- ◆ Once the speed exceed 45M/min, the incline angle should be reduced 5% for each 5M/min acceleration.

* In special high/low temperature environment, rubber cover (TPE) is not available for use.

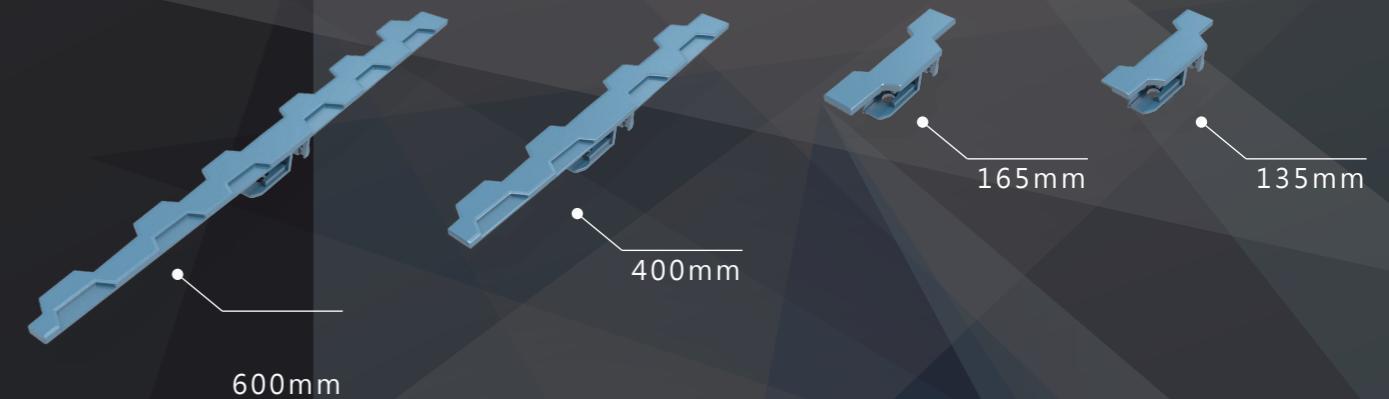
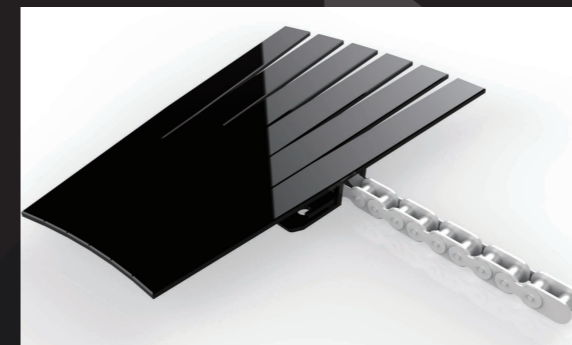
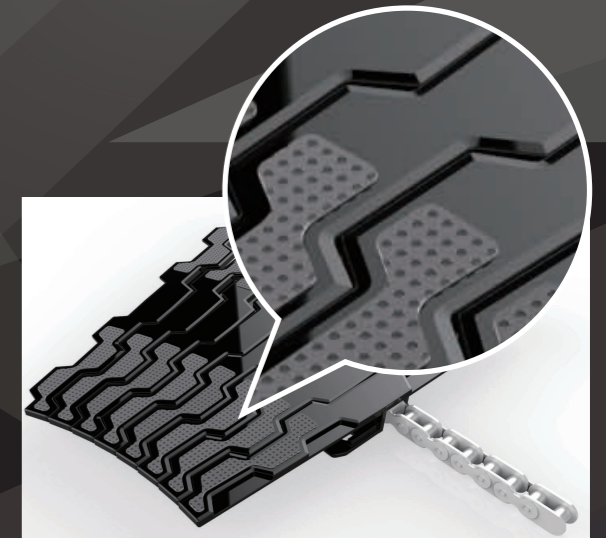

Flexible connections

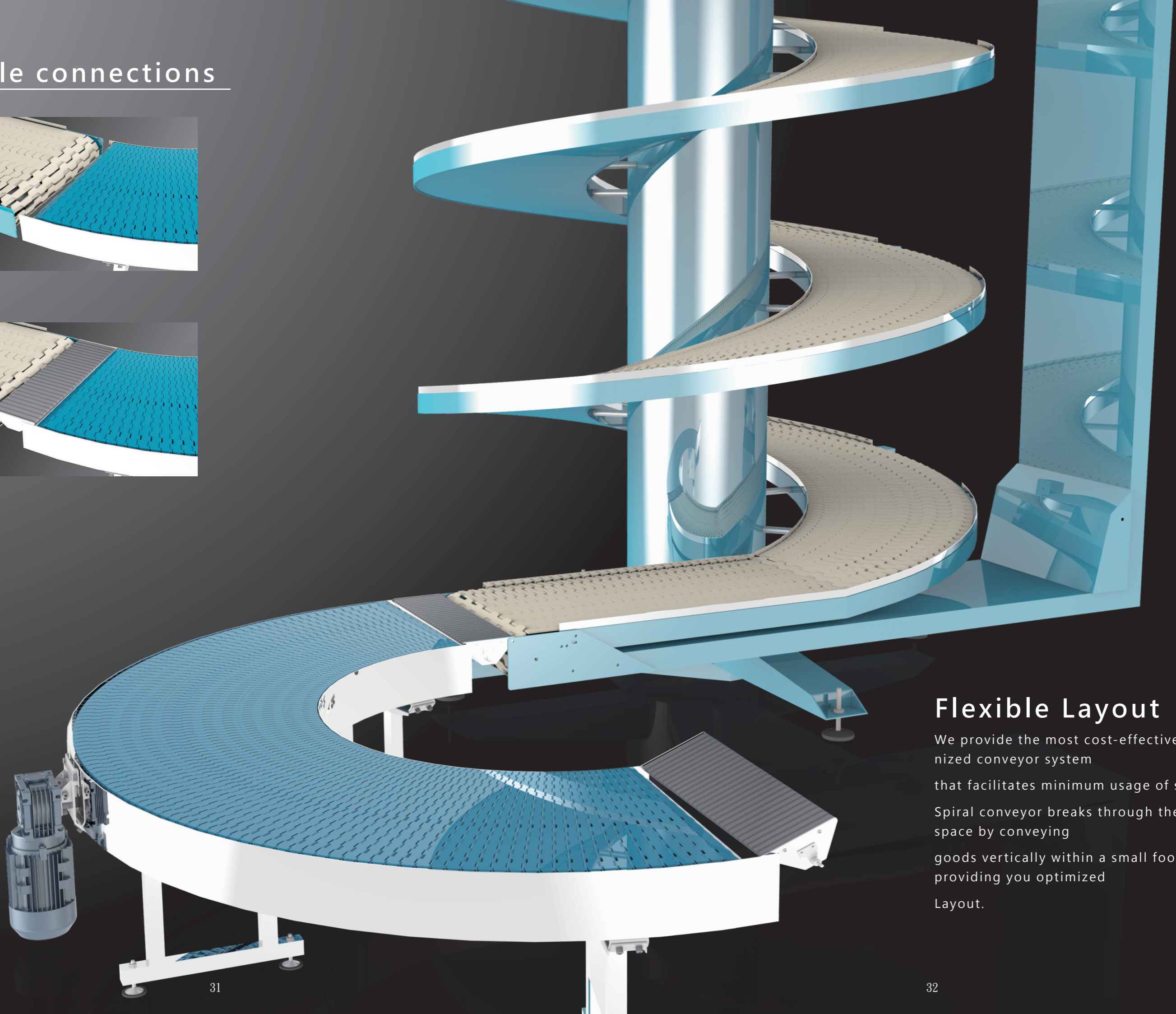
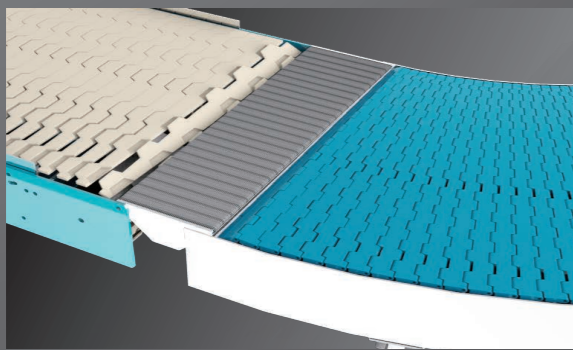
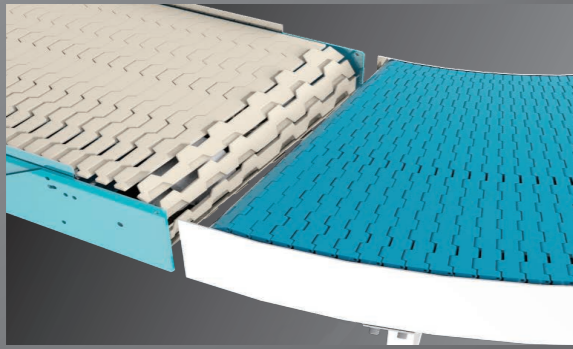

Flexible Layout

We provide the most cost-effective organized conveyor system that facilitates minimum usage of space. Spiral conveyor breaks through the limit of space by conveying goods vertically within a small footprint, providing you optimized Layout.



NEXUS

TEL : +886 6 5898701

FAX : +886 6 5894970

Website : www.nexus-spiral.com

E-mail : service@nexus-spiral.com

No.477-1, Dashe, Xinshi Dist.,

Tainan City 744, Taiwan(ROC)